

General Features

The D503 is an easy to configure Ethernet-to-MVB gateway. It provides a line redundant MVB interface as well as up to two 10/100 Mb/s Ethernet interfaces (ETH0 / ETH1). The Ethernet connectors comply with IEC 61076-2-101 (D-coded; female).

The Ethernet interfaces comply with IEEE 802.3 supporting 10BASE-T or 100BASE-TX, full duplex mode, auto-negotiation and auto MDI-X. Furthermore, the internal logic supports the "Ethernet on traction vehicles" standard IEC 61375-3-4.

The optional second Ethernet interface ETH1 is intended to be used as a redundant line or as a separate channel for remote diagnostic and maintenance purposes.

The MVB interface complies with the TCN standard IEC 61375 and supports devices up to class 4 including process and message data. Optionally, the device may act as a bus administrator.

duagon's gateways are available with two variants – as platform to build a customer-specific application or as gateway with a standard configurable gateway application. The platform variant is accompanied by a development library that enables fast and efficient design of customer-specific applications.

The gateway is integrated in a stainless-steel housing that can be mounted on a DIN rail or using M4 screws. The device can be powered directly from the vehicle battery or by Power over Ethernet (PoE).

The D503 is designed for the harsh traction environment and conforms to the EN 50155, EN 50121, and IEC 61373 standards in general, but particularly by:

- -40 °C to +70 °C ambient temperature range
- Interruption voltage supply class S2
- Coating against humidity
- Enhanced EMI and vibration robustness

The D500 Ethernet gateway series covers the following train communication networks:

- D501 Ethernet – RS232 Gateway
- D502 Ethernet – RS485/RS422 Gateway
- D503 Ethernet – MVB Gateway (this document)
- D504 Ethernet – CAN Gateway
- D507 Ethernet – Ethernet Gateway (protocol translation)

Key Benefits

- Proprietary high-performance Ethernet communication stack; optimised for cyclic process data.
- Support for most common real-time Ethernet protocols including TRDP, IPTCom and EtherNet/IP – CIP.
- Optional redundant Ethernet interface.
- Support for MVB devices up to class 4, including bus administrator functionality, process and message data.
- duagon web server for remote diagnostics and firmware updates; possibility to implement customer-specific web pages. Standard C development library to design customer-specific gateway application.

Application Examples

- Retrofitting of existing train communication networks based on legacy field buses.
- Accessing train communication networks for diagnostic and maintenance purposes from train operator or IT networks.

D503 Hardware Architecture

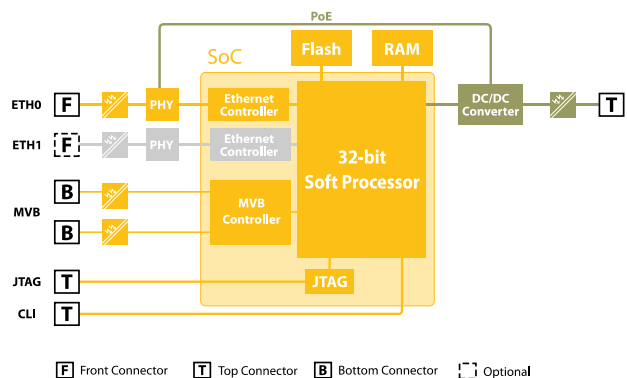

Technical Data

Ethernet Interface	<ul style="list-style-type: none"> – 100BASE-TX or 10BASE-T physical layer according to IEEE 802.3 – M12 connectors (female, D-Coded) according to IEC 61076-2-101 – Support for full duplex mode, auto-negotiation, auto MDI-X – 1.5 kVAC galvanic isolation
Ethernet Protocols	<ul style="list-style-type: none"> – TCP/IP, UDP Sockets – IPTCom – EtherNet/IP - CIP – TRDP – PROFINET*
MVB Interface	<ul style="list-style-type: none"> – 4096 process data ports – Support for both ESD+ and EMD physical layers – Integrated 120 Ω termination resistance – Two 9-pin SUB-D connectors (male/female) – Free selectable UNC or M3 bolts (default)
CPU base System	<ul style="list-style-type: none"> – 32-bit soft processor – Programmable in standard C with accompanying development library – Flash file system

Diagnostic / Service	<ul style="list-style-type: none"> – Device status information available through serial interface, telnet or web server – Firmware update via Ethernet – JTAG and serial line externally accessible
Supply Voltage	<ul style="list-style-type: none"> – Single power supply 24 – 110 V DC – Power over Ethernet (PoE), PD
Power Consumption	<ul style="list-style-type: none"> – Powered directly from battery $P_{max} < 3 W$ – Interruption voltage supply Class S2
Operating Conditions	<ul style="list-style-type: none"> – Ambient temperature: –40 to +70 °C (EN 50155, Class TX) – Relative humidity: 75%, max. 95% for 30 days per year (conformal coating) according to EN 60068 – Shock and vibration: According to IEC 61373 category 1, Class B – EMI: According to EN 50121 and EN 50155
Physical Characteristics	<ul style="list-style-type: none"> – Housing: Stainless steel, ingress protection IP30 – Dimensions: 120 × 106 × 32 mm – Weight: 415 g (may vary depending on the selected configuration)
Environment	<ul style="list-style-type: none"> – Fully compliant with RoHS and REACH – 100% cyclic climatic testing

d-023708-047643

Product Ordering Table

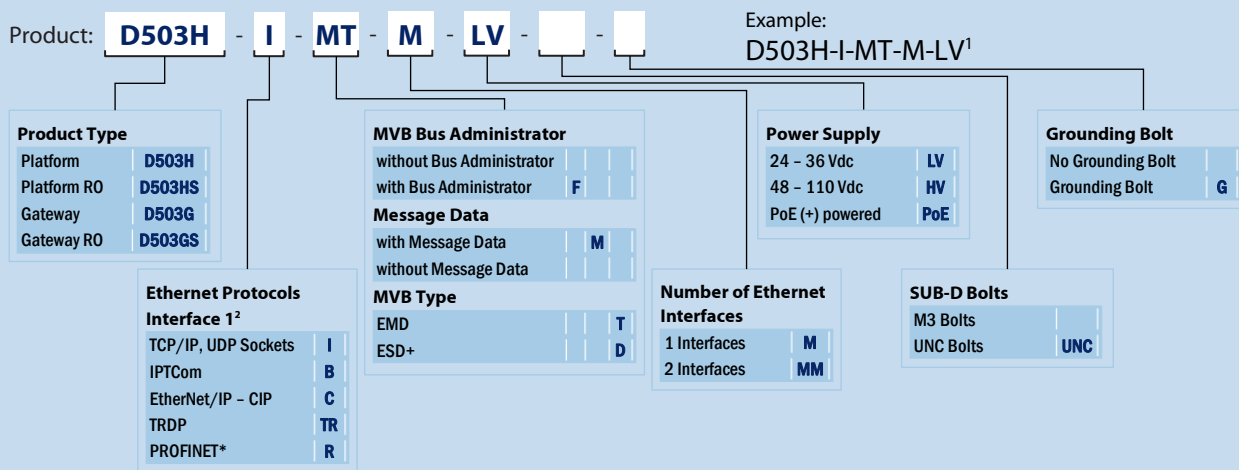

¹ default order options

² Ethernet "Sockets" is included on all interfaces

* contact duagon for lead times and availability

Related Documents

Data Sheet D503 D503_DS.pdf
Product Ordering Guide order_ug.pdf

available at www.duagon.com

duagon AG
 Riedstrasse 12
 CH-8953 Dietikon
 Phone +41 44 743 73 00
 Fax +41 44 743 73 15

www.duagon.com

